

VocoPro®

THE SINGER'S ULTIMATE CHOICE™

FEATURES:

- 100W + 100W maximum power output Mixing Amplifier
- 9-step Digital Key Controller for transposing natural key of source music
- Digital Echo with Repeat and Delay controls to add depth and space to vocals
- Three Microphone Inputs with individual Volume controls
- Full-function remote control for ease of operation
- Master Music and Microphone Volume controls
- Four dedicated RCA L/R audio input channels
- Four RCA style Video Inputs and Two Video Outputs

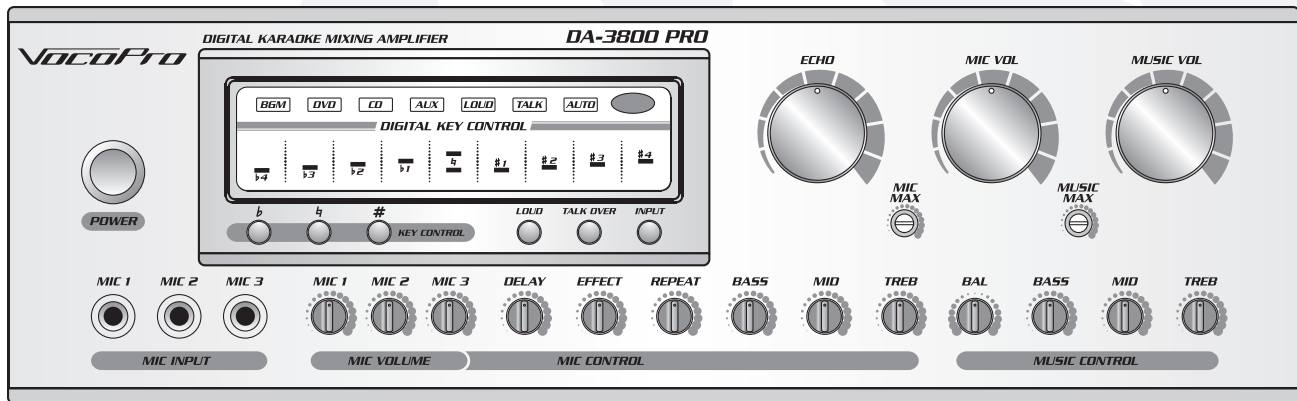
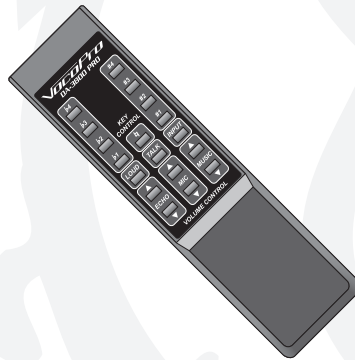

DA-3800 PRO

Digital Karaoke Mixing Amplifier

o w n e r ' s m a n u a l

Table of Contents

Introduction

Safety instructions	2
FCC Information	3
Welcome	4
Listening for a lifetime	5
Before getting started.....	6

Getting Connected

Remote and Power Cable	7
Speakers.....	8
Connecting input source players	9-13
Connecting TV's/monitors	14

Descriptions and Functions

Front panel.....	15-17
Rear panel	18-19
Remote Control.....	20
Display Panel	21

Specifications.....	22
---------------------	----

Troubleshooting.....	23
----------------------	----



Safety Instructions



CAUTION
RISK OF SHOCK



CAUTION: To reduce the risk of electric shock, do not remove cover (or back). No user-serviceable parts inside. Only refer servicing to qualified service personnel.

Explanation of Graphical Symbols



The lightning flash & arrowhead symbol, within an equilateral triangle, is intended to alert you to the presence of danger.



The exclamation point within an equilateral triangle is intended to alert you to the presence of important operating and servicing instructions.

WARNING

To reduce the risk of fire or electric shock, do not expose this unit to rain or moisture.

1. Read Instructions - All the safety and operating instructions should be read before the appliance is operated.

2. Retain Instructions - The safety and operating instructions should be retained for future reference.

3. Heed Warnings - All warnings on the appliance and in the operating instructions should be adhered to.

4. Follow Instructions - All operating and use instructions should be followed.

5. Attachments - Do not use attachments not recommended by the product manufacturer as they may cause hazards.

6. Water and Moisture - Do not use this unit near water. For example, near a bathtub or in a wet basement and the like.

7. Carts and Stands - The appliance should be used only with a cart or stand that is recommended by the manufacturer.

7 A. An appliance and cart combination should be moved with care. Quick stops, excessive force, and uneven surfaces may cause an overturn.



8. Ventilation - The appliance should be situated so its location does not interfere with its proper ventilation. For example, the appliance should not be situated on a bed, sofa, rug, or similar surface that may block the ventilation slots.

9. Heat - The appliance should be situated away from heat sources such as radiators, heat registers, stoves, or other appliances (including amplifiers) that produce heat.

10. Power Sources - The appliance should be connected to a power supply only of the type described in the operating instructions or as marked on the appliance.

11. Grounding or Polarization - Precautions should be taken so that the grounding or polarization means of an appliance is not defeated.

12. Power-Cord Protection - Power-supply cords should be routed so that they are not likely to be walked on or pinched by items placed upon or against them, paying particular attention to cords at plugs, convenience receptacles, and the point where they exit from the appliance.

13. Cleaning - Unplug this unit from the wall outlet before cleaning. Do not use liquid cleaners or aerosol cleaners. Use a damp cloth for cleaning.

14. Power lines - An outdoor antenna should be located away from power lines.

15. Nonuse Periods - The power cord of the appliance should be unplugged from the outlet when left unused for a long period of time.

16. Object and Liquid Entry - Care should be taken so that objects do not fall and liquids are not spilled into the enclosure through openings.

17. Damage Requiring Service - The appliance should be serviced by qualified service personnel when:

- A. The power supply cord or plug has been damaged; or
- B. Objects have fallen into the appliance; or
- C. The appliance has been exposed to rain; or
- D. The appliance does not appear to operate normally or exhibits a marked change in performance; or
- E. The appliance has been dropped, or the enclosure damaged.

18. Servicing - The user should not attempt to service the appliance beyond that described in the operating instructions. All other servicing should be referred to qualified service personnel.

Note:

To CATV system installer's (U.S.A.): This reminder is provided to call the CATV system installer's attention to Article 820-40 of the NEC that provides guidelines for proper grounding and, in particular, specifies that the cable ground shall be connected as close to the point of cable entry as practical.

FCC INFORMATION (U.S.A.)

1. IMPORTANT NOTICE: DO NOT MODIFY THIS

UNIT!: This product, when installed as indicated in the instructions contained in this manual, meets FCC requirements. Modifications not expressly approved by Vocopro may void your authority, granted by the FCC, to use this product.

2. IMPORTANT: When connecting this product to accessories and/or another product use only high quality shielded cables. Cable(s) supplied with this product **MUST** be used. Follow all installation instructions. Failure to follow instructions could void your FCC authorization to use this product in the U.S.A.

3. NOTE: This product has been tested and found to comply with the requirements listed in FCC Regulations, Part 15 for Class "B" digital devices. Compliance with these requirements provides a reasonable level of assurances that your use of this product in a residential environment will not result in harmful interference with other electronic devices. This equipment generates/uses radio frequencies and, if not installed and used according to the instructions found in the owner's manual, may cause interference harmful to the operation of other electronic devices. Compliance with FCC regulations does not guarantee that interference will not occur in all installations. If this product is found to be the source of interference, which can be determined by turning the unit "Off" and "On", please try to eliminate the problem by using one of the following measures:

Relocate either this product or the device that is being affected by the interference.

Use power outlets that are on different branch (circuit breaker or fuse) circuits or install AC line filter(s).

In the case of radio or TV interference, relocate/reorient the antenna. If the antenna lead-in is 300-ohm ribbon lead, change the lead-in to coaxial type cable.

If these corrective measures do not produce satisfactory results, please contact your local retailer authorized to distribute Vocopro products. If you can not locate the appropriate retailer, please contact Vocopro, 1728 Curtiss Court, La Verne, CA 91750.

CAUTION

The apparatus is not disconnected from the AC power source so long as it is connected to the wall outlet, even if the apparatus itself is turned off. To fully insure that the apparatus is indeed fully void of residual power, leave unit disconnected from the AC outlet for at least fifteen seconds.

CAUTION:

READ THIS BEFORE OPERATING YOUR UNIT

1. To ensure the finest performance, please read this manual carefully. Keep it in a safe place for future reference.
2. Install your unit in a cool, dry, clean place - away from windows, heat sources, and too much vibration, dust, moisture or cold. Avoid sources of hum (transformers, v motors). To prevent fire or electrical shock, do not expose to rain and water.
3. Do not operate the unit upside-down.
4. Never open the cabinet. If a foreign object drops into the set, contact your dealer.
5. Place the unit in a location with adequate air circulation. Do not interfere with its proper ventilation; this will cause the internal temperature to rise and may result in a failure.
6. Do not use force on switches, knobs or cords. When moving the unit, first turn the unit off. Then gently disconnect the power plug and the cords connecting to other equipment. Never pull the cord itself.
7. Do not attempt to clean the unit with chemical solvents: this might damage the finish. Use a clean, dry cloth.
8. Be sure to read the "Troubleshooting" section on common operating errors before concluding that your unit is faulty.
9. This unit consumes a fair amount of power even when the power switch is turned off. We recommend that you unplug the power cord from the wall outlet if the unit is not going to be used for a long time. This will save electricity and help prevent fire hazards. To disconnect the cord, pull it out by grasping the plug. Never pull the cord itself.
10. To prevent lightning damage, pull out the power cord and remove the antenna cable during an electrical storm.
11. The general digital signals may interfere with other equipment such as tuners or receivers. Move the system farther away from such equipment if interference is observed.

NOTE:

Please check the copyright laws in your country before recording from records, compact discs, radio, etc. Recording of copyrighted material may infringe copyright laws.

Voltage Selector (General Model Only)

Be sure to position the voltage selector to match the voltage of your local power lines before installing the unit.

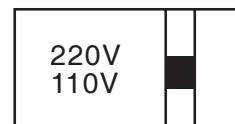



Welcome

And thank you for purchasing the **DA-3800 PRO** from VocoPro, your ultimate choice in Karaoke entertainment! With years of experience in the music entertainment business, VocoPro is a leading manufacturer of Karaoke equipment, and has been providing patrons of bars, churches, schools, clubs and individual consumers the opportunity to sound like a star with full-scale club models, in-home systems and mobile units. All our products offer solid performance and sound reliability, and to reinforce our commitment to customer satisfaction, we have customer service and technical support professionals ready to assist you with your needs. We have provided some contact information for you below.

VocoPro

1728 Curtiss Court
La Verne, CA 91750

Toll Free: 800-678-5348

TEL: 909-593-8893

FAX: 909-593-8890

VocoPro Company Email Directory

Customer Service & General Information

info@vocopro.com

Tech Support

techsupport@vocopro.com

Remember Our Website

Be sure to visit the VocoPro website **www.vocopro.com** for the latest information on new products, packages and promos. And while you're there don't forget to check out our Club VocoPro for Karaoke news and events, chat rooms, club directories and even a KJ Service directory!

We look forward to hearing you sound like a PRO, with VocoPro, the singer's ultimate choice.

FOR YOUR RECORDS

Please record the model number and serial number below, for easy reference, in case of loss or theft. These numbers are located on the rear panel of the unit. Space is also provided for other relevant information

Model Number _____

Serial Number _____

Date of Purchase _____

Place of Purchase _____

Listening for a lifetime

Selecting fine audio equipment such as the unit you've just purchased is only the start of your musical enjoyment. Now it's time to consider how you can maximize the fun and excitement your equipment offers. VocoPro and the Electronic Industries Association's Consumer Electronics Group want you to get the most out of your equipment by playing it at a safe level. One that lets the sound come through loud and clear without annoying blaring or distortion and, most importantly, without affecting your sensitive hearing.

Sound can be deceiving. Over time your hearing 'comfort level' adapts to a higher volume of sound. So what sounds 'normal' can actually be loud and harmful to your hearing. Guard against this by setting your equipment at a safe level BEFORE your hearing adapts.

To establish a safe level:

- Start your volume control at a low setting.
- Slowly increase the sound until you can hear it comfortably and clearly, and without distortion.

Once you have established a comfortable sound level:

- Set the dial and leave it there.
- Pay attention to the different levels in various recordings.

Taking a minute to do this now will help to prevent hearing damage or loss in the future. After all, we want you listening for a lifetime.

Used wisely, your new sound equipment will provide a lifetime of fun and enjoyment. Since hearing damage from loud noise is often undetectable until it is too late, this manufacturer and the Electronic Industries Association's Consumer Electronics Group recommend you avoid prolonged exposure to excessive noise. This list of sound levels is included for your protection.

Some common decibel ranges:

Level	Example
30	Quiet library, Soft whispers
40	Living room, Refrigerator, Bedroom away from traffic
50	Light traffic, Normal Conversation
60	Air Conditioner at 20 ft., Sewing machine
70	Vacuum cleaner, Hair dryer, Noisy Restaurant
80	Average city traffic, Garbage disposals, Alarm clock at 2 ft.

The following noises can be dangerous under constant exposure:

Level	Example
90	Subway, Motorcycle, Truck traffic, Lawn Mower
100	Garbage truck, Chainsaw, Pneumatics drill
120	Rock band concert in front of speakers
140	Gunshot blast, Jet plane
180	Rocket launching pad

-Information courtesy of the Deafness Research Foundation

Before Getting Started

Thank you for purchasing the DA-3800 PRO Digital Karaoke Mixing Amplifier. The DA-3800 PRO will provide years of reliability and high quality entertainment for you if used properly. Please read this manual carefully before using your DA-3800 PRO to ensure best performance.

Unpacking the DA-3800 PRO

Carefully remove the DA-3800 PRO from its carton. It is recommended that you store the original packaging materials in case you need to ship this equipment for any reason.

Be sure you have the following parts and components included with your DA-3800 PRO:

ITEMS:	QUANTITY:
DA-3800 PRO	1
Video/Stereo RCA Patch Cable	1
Remote Control	1
AA Batteries	2
AC Power Cable	1
Rack Brackets	2

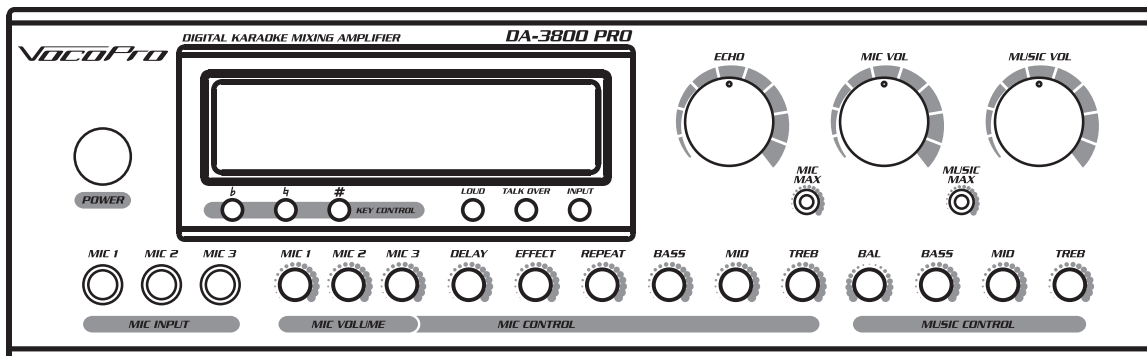
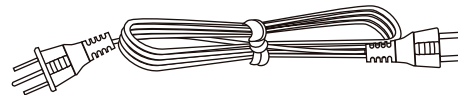
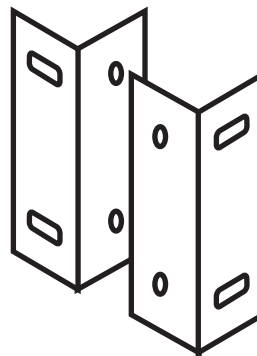
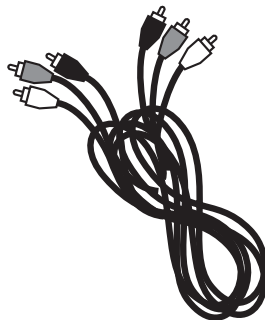
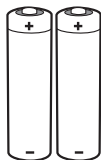
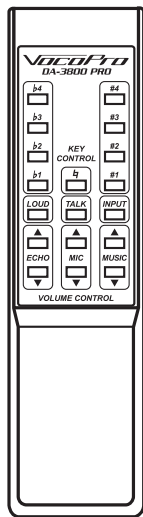

Getting Connected

About the Remote Control

- The area between the remote control and the main unit must be clear of large obstacles.
- Do not expose the remote control sensor to strong lighting, especially an inverter type fluorescent lamp as this may cause the remote control to not function properly.

Installing Batteries in the Remote Control

1. Turn the remote control over and slide the battery compartment cover off towards the direction of the arrow.
2. Insert the AA batteries, positioning them according to the polarity (+, -) markings on the inside of the battery compartment.
3. Close the battery compartment cover.

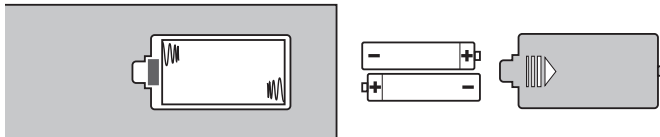

Battery Replacement

If you find that the distance between the remote control and the main unit must be shorter in order to use the remote control, this means that the batteries are low and must be changed. Replace both batteries with new ones.

Battery Notes:

- Use AA batteries.
- Be sure the polarities (+, -) are correct. (See the illustration inside the battery compartment).
- Remove the batteries when not using the remote control for an extended period of time.
- If batteries leak, dispose of them immediately. Avoid skin, clothing and any other contact with the leaked material. Clean the battery compartment thoroughly before installing new batteries.
- Do not mix old and new batteries.
- Do not mix alkaline, standard (carbon-zinc) with rechargeable (nickel-cadmium) batteries.

Connecting the Power Cable

Plug the supplied AC power cable into the AC inlet after all other connections are complete and then plug the AC power cable to an AC wall outlet.

CAUTION

Use the supplied AC cable. Do not use other AC power cables as doing so may result in fire hazard or electrical shock.

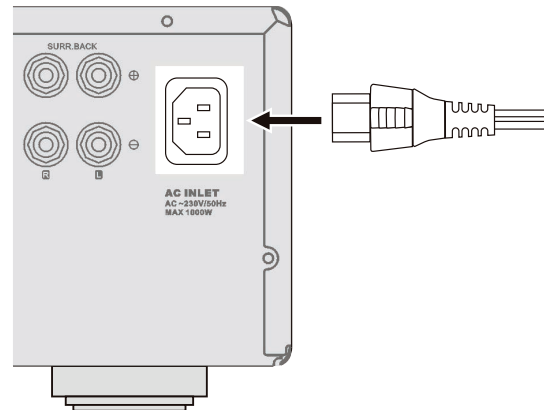

Image shown is a generic model for reference.

Getting Connected

Connecting Speakers

The Speaker Terminals are located on the rear panel. There are two STEREO terminals. Be sure to connect the left channel (L), right channel (R), "+" (red) and "-" (black) properly.

DA-3800PRO rear panel

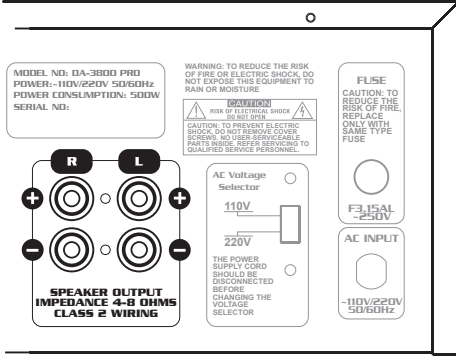

- Before connecting the speakers, make sure that the DA-3800 PRO is disconnected from the power source.
- Do not let the bare speaker wires touch each other or another metal part of this unit. This could damage the DA-3800 PRO and/or the speakers.

Determining the proper way to connect the speaker cables:

The speaker cable is a pair of insulated cables running side by side. One cable is colored or shaped differently, perhaps with a stripe, groove or ridges.

1. Connect one end of the striped (grooved, ridged, etc.) cable to the "+" (red) terminal on the rear panel of the DA-3800 PRO.
2. Connect the other end of the striped (grooved, ridged, etc.) cable to the "+" (red) terminal on the speaker.
3. Connect one end of the "plain" (NO stripes, grooves, ridges, etc.) cable to the "-" (black) terminal on the rear panel of the DA-3800 PRO.
4. Connect the other end of the "plain" (NO stripes, grooves, ridges, etc.) cable to the "-" (black) terminal on the speaker

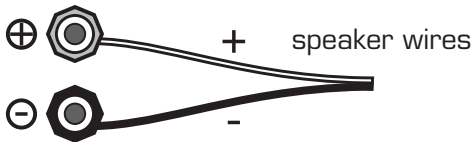

DA-3800 PRO connectors

Preparing the Speaker Cable

You can either use an exposed speaker wire or Banana Plug speaker cable.

Exposed Speaker Wire

1. Remove approximately 3/8" (10mm) of insulation

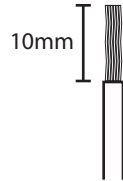

2. Twist the exposed wires together to prevent short circuits

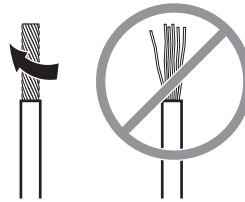

3. Loosen the knob on the speaker terminal
4. Insert the bare wire
5. Tighten the knob until the wire is secure

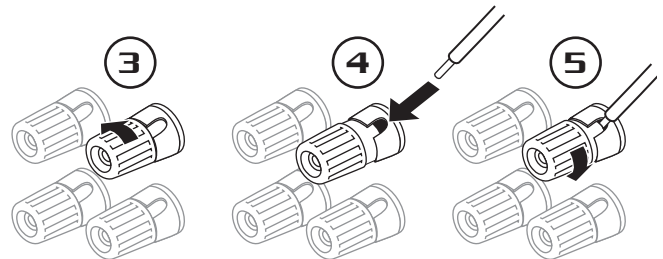

Banana Connector

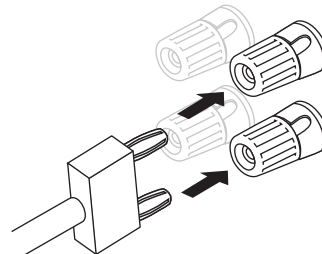

Getting Connected cont.

Connecting to the REC OUT or LINE OUT jacks

The L/R (red and white) RCA Record Output or Line Output jacks on the rear panel can be connected to any self-powered input device with RCA inputs. (i.e. recording device, powered speakers, etc)

What you will need:

- Powered device with L/R RCA inputs
- RCA L/R audio cable (red & white)

1. Connect one end of the red and white RCA cable to the REC OUT jacks on the DA-3800 PRO's rear panel
2. Connect the other end of the red and white RCA cable to the RCA inputs on the recording device, powered speakers, etc.

DA-3800 PRO rear panel

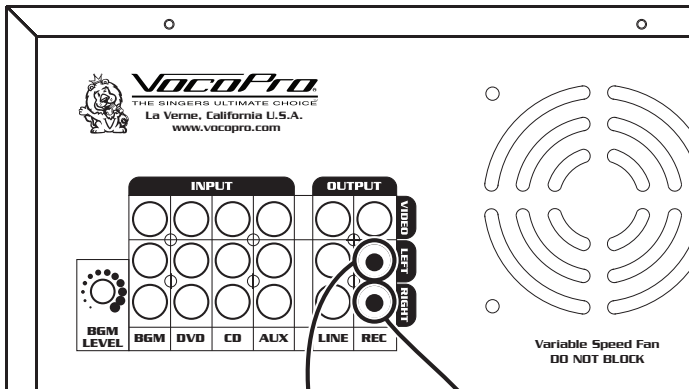

DA-3800 PRO rear panel

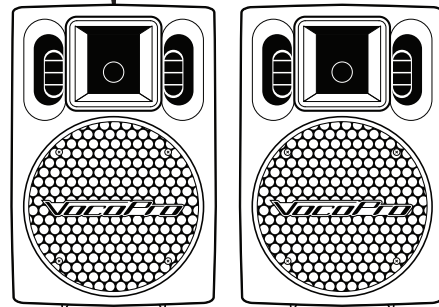
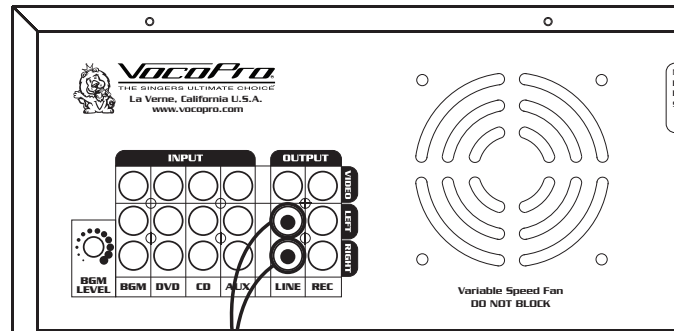

PV-802 Powered Speakers

CDR-1000 PRO rear panel

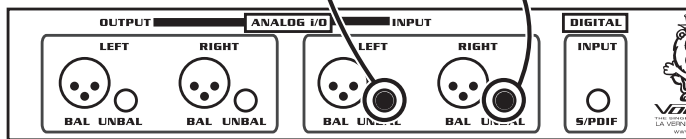

Getting Connected cont.

Connecting to the DA-3800 PRO's Inputs

There are four available A/V input channels which allow you to connect up to four A/V players to the DA-3800 PRO: BGM, DVD, CD, and AUX.

Connecting a DVD, CD or other A/V Player with RCA Audio and Video Outputs to the BGM Input

A DVD, CD or other A/V player can be connected to the BGM inputs using the L/R (red & white) RCA audio inputs and the RCA video (yellow) input.

What you will need

- Player with RCA audio and video outputs
- RCA L/R audio cable (red & white)
- RCA video cable (yellow)

Audio

1. Connect one end of the red and white RCA audio cable to the L/R audio outputs on your player
2. Connect the other end of the red and white RCA audio cable to the BGM L/R audio inputs on the DA-3800 PRO rear panel

Video

1. Connect one end of the RCA video cable to the RCA video output on your player
2. Connect the other end of the RCA video cable to one of the RCA video inputs on the DA-3800 PRO's rear panel
3. Select the proper input channel on the DA-3800 PRO.

NOTE: All four of the A/V input channels have RCA audio and video inputs so make sure the correct one is selected.

Selecting the Correct input channel

Front panel: Press the INPUT button on the DA-3800 PRO front panel until the BGM input channel is displayed on the screen

Remote Control: Press the input button on the remote control until the BGM input channel is displayed on the screen

DA-3800 PRO rear panel

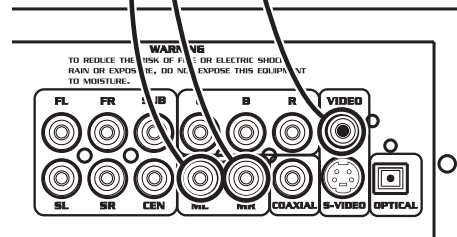
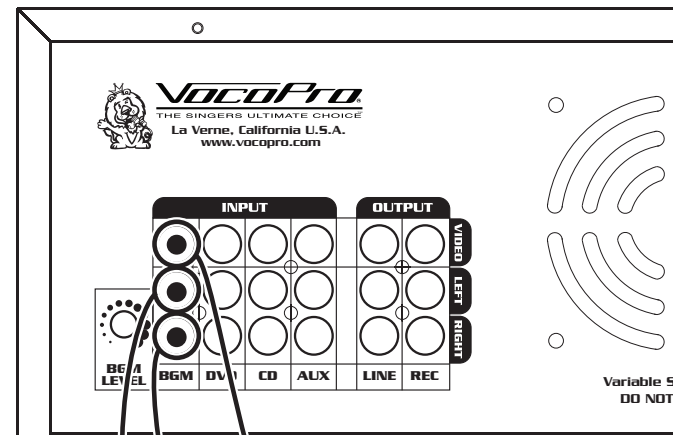

DVG-888K dvd player rear panel

Getting Connected cont.

Connecting a DVD Player with RCA Audio and Video Outputs to the DVD Input

A DVD player can be connected to the DVD inputs using the L/R (red & white) RCA audio inputs and the RCA video (yellow) input.

What you will need

- Player with RCA audio and video outputs
- RCA L/R audio cable (red & white)
- RCA video cable (yellow)

Audio

1. Connect one end of the red and white RCA audio cable to the L/R audio outputs on your player
2. Connect the other end of the red and white RCA audio cable to the DVD L/R audio inputs on the DA-3800 PRO rear panel

Video

1. Connect one end of the RCA video cable to the RCA video output on your player
2. Connect the other end of the RCA video cable to the DVD RCA video inputs on the DA-3800 PRO's rear panel
3. Select the proper input channel on the DA-3800 PRO.

NOTE: All four of the A/V input channels have RCA audio and video inputs so make sure the correct one is selected.

Selecting the Correct input channel

Front panel: Press the INPUT button on the DA-3800 PRO front panel until the DVD input channel is displayed on the screen

Remote Control: Press the input button on the remote control until the DVD input channel is displayed on the screen

DA-3800 PRO rear panel

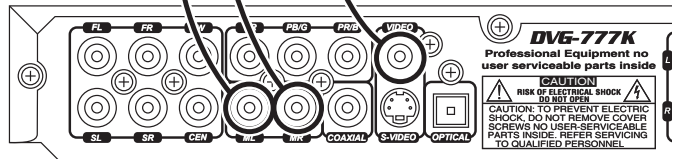
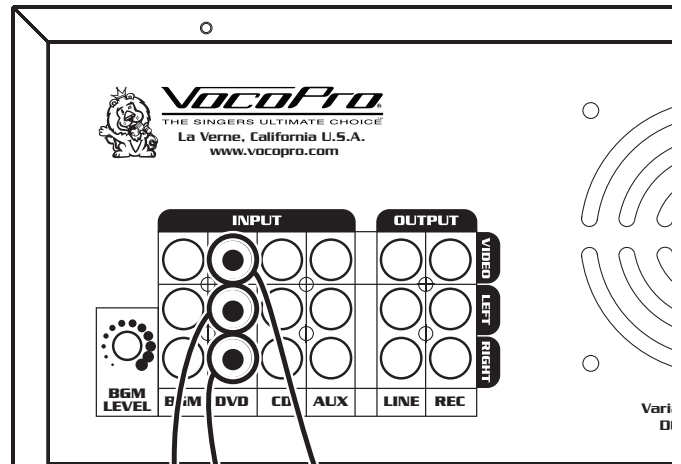

DVG-777K dvd player rear panel

Getting Connected cont.

Connecting a CD Player with RCA Audio and Video Outputs to the CD Input

A CD player can be connected to the CD inputs using the L/R (red & white) RCA audio inputs and the RCA video (yellow) input.

What you will need

- Player with RCA audio and video outputs
- RCA L/R audio cable (red & white)
- RCA video cable (yellow)

Audio

1. Connect one end of the red and white RCA audio cable to the L/R audio outputs on your player
2. Connect the other end of the red and white RCA audio cable to the CD L/R audio inputs on the DA-3800 PRO rear panel

Video

1. Connect one end of the RCA video cable to the RCA video output on your player
2. Connect the other end of the RCA video cable to the CD RCA video inputs on the DA-3800 PRO's rear panel
3. Select the proper input channel on the DA-3800 PRO.

NOTE: All four of the A/V input channels have RCA audio and video inputs so make sure the correct one is selected.

Selecting the Correct input channel

Front panel: Press the INPUT button on the DA-3800 PRO front panel until the CD input channel is displayed on the screen

Remote Control: Press the input button on the remote control until the CD input channel is displayed on the screen

DA-3800 PRO rear panel

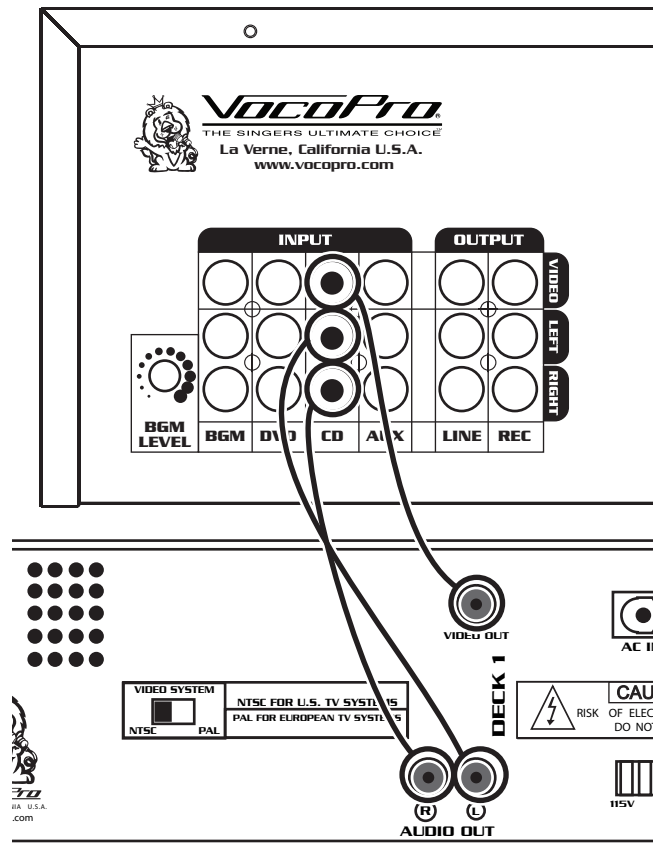

CDG-9000 PRO cd+g player rear panel

Getting Connected cont.

Connecting a AUXILIARY Player with RCA Audio and Video Outputs to the AUX Input

A DVD, CD or other A/V player can be connected to the AUX inputs using the L/R (red & white) RCA audio inputs and the RCA video (yellow) input.

What you will need

- Player with RCA audio and video outputs
- RCA L/R audio cable (red & white)
- RCA video cable (yellow)

Audio

1. Connect one end of the red and white RCA audio cable to the L/R audio outputs on your player
2. Connect the other end of the red and white RCA audio cable to the AUX L/R audio inputs on the DA-3800 PRO rear panel

Video

1. Connect one end of the RCA video cable to the RCA video output on your player
2. Connect the other end of the RCA video cable to the AUX RCA video inputs on the DA-3800 PRO's rear panel
3. Select the proper input channel on the DA-3800 PRO.

NOTE: All four of the A/V input channels have RCA audio and video inputs so make sure the correct one is selected.

Selecting the Correct input channel

Front panel: Press the INPUT button on the DA-3800 PRO front panel until the AUX input channel is displayed on the screen

Remote Control: Press the input button on the remote control until the AUX input channel is displayed on the screen

DA-3800 PRO rear panel

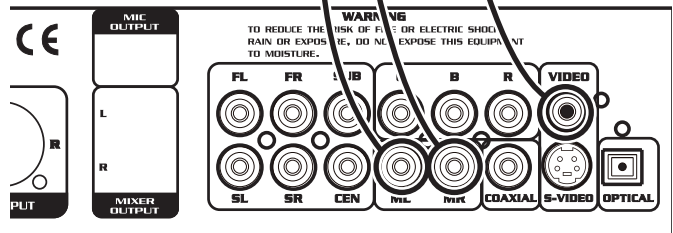
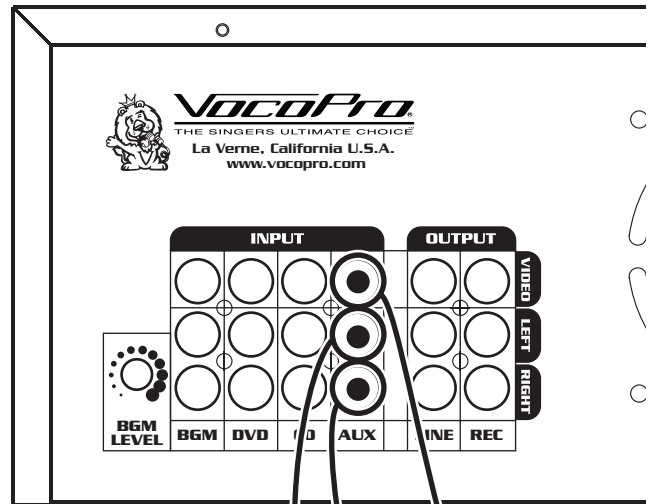

DVG-888K dvd player rear panel

Getting Connected cont.

Connecting to a TV using the RCA Video (yellow) Output

What you will need

- TV/ video monitor with an RCA video input
- RCA video cable (yellow)

1. Connect one end of the RCA video cable to either of the two RCA video OUT jack on the DA-3800 PRO rear panel
2. Connect the other end of the RCA video cable to the RCA video input on the TV/Video monitor
3. Make sure the TV/Video monitor is set to the correct video input. Consult the TV/Video monitor's user manual for the necessary instructions

DA-3800 PRO rear panel

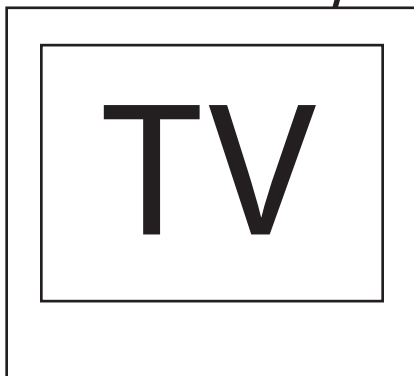
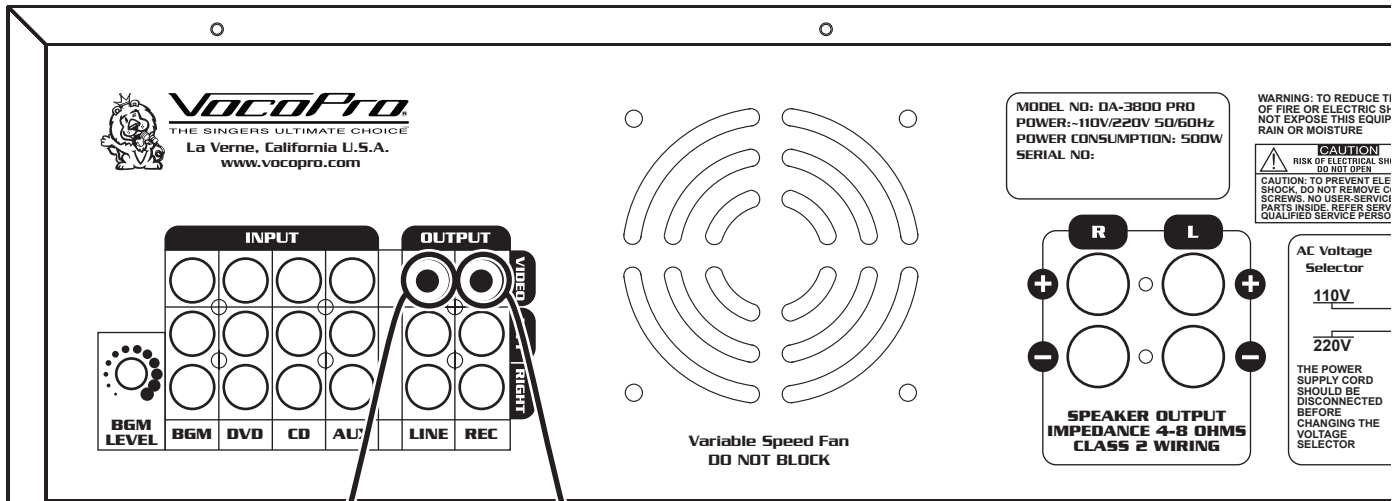

Television

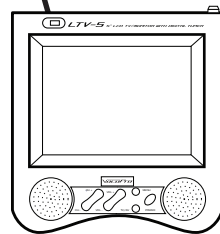

LTV-5 monitor

Front Panel Descriptions and Functions

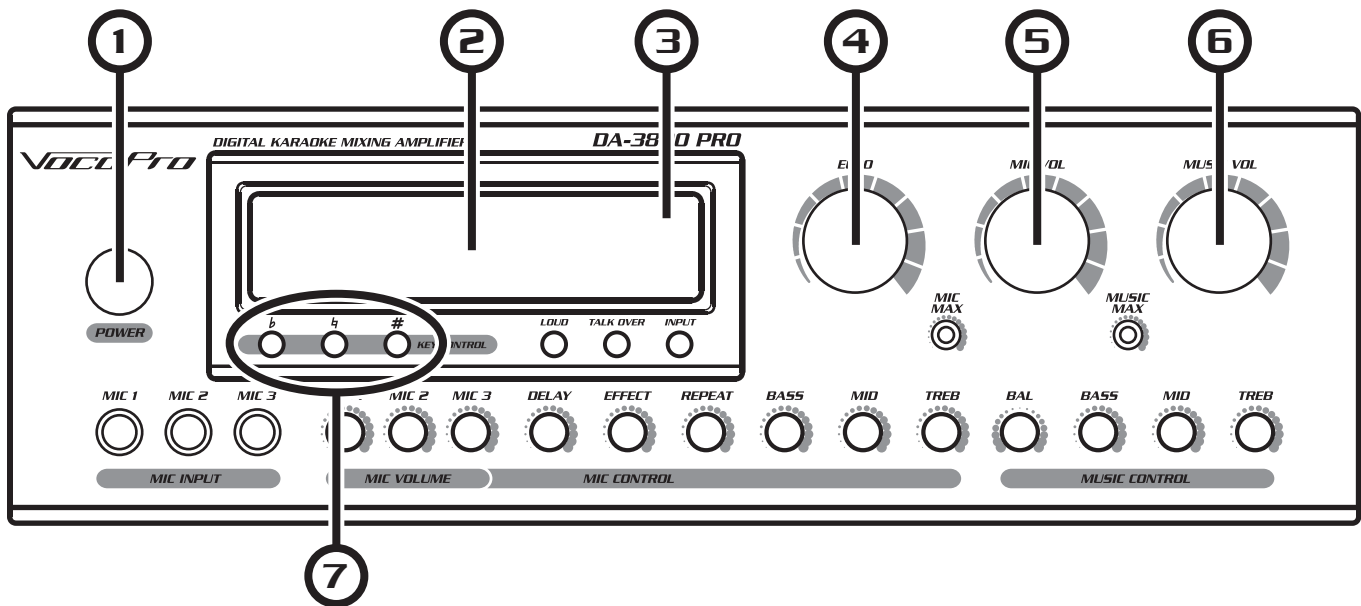

1. **POWER** - Use this button to turn the DA-3800 PRO ON or OFF.
2. **DISPLAY** - Displays setting information (i.e. KEY CONTROL, AUTO, LOUD, TALK).
3. **REMOTE SENSOR** - When operating the DA-3800 PRO with the REMOTE CONTROL, direct the REMOTE towards this SENSOR within 23 feet. Maintain a line of sight between REMOTE and REMOTE SENSOR clear of obstacles to prevent signal blockage.
4. **ECHO** - This controls the overall level for the ECHO effect on all three MIC INPUTS. This effect gives a spacious or ambient feeling that works great with vocals. Rotate clockwise to increase the amount of ECHO effect applied to the signal, and counter-clockwise to decrease.
5. **MIC VOLUME** - This control adjusts the output level for MIC 1, 2 and 3. Turn clockwise to increase output and counter-clockwise to decrease.
6. **MUSIC VOLUME** - This control adjusts the output level for whichever player connected to an AUDIO INPUT and assigned with the INPUT selector. Turn clockwise to increase output and counter-clockwise to decrease.
7. **DIGITAL KEY CONTROL** - Adjust the key of your source music in half-step increments to match the natural range of your voice using these buttons.
 - b* Flat - lower the key.
 - #* Sharp - raise the key.
 - ♮* Natural - return to the original key of the music input source.

You will see the DISPLAY reflect the KEY CONTROL step you have selected. The increase in numbers for both flat (*b*) and sharp (*#*) represent an increase in amount of key change from the original or natural, 1 being the least amount, 4 being the most.

Front Panel Descriptions and Functions cont.

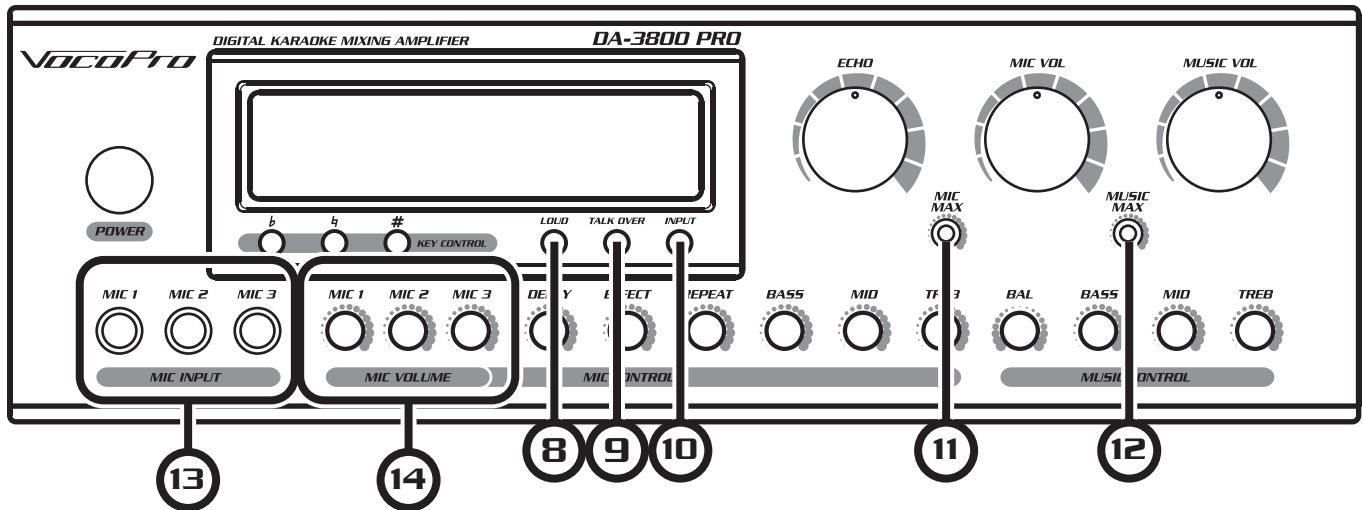

- 8. LOUD (LOUDNESS CONTROL)** - For an instant music Volume/Gain, the LOUD button is an easy way to improve your mix when you need an extra boost. Perfect for varying volume controls between tracks or singers.
- 9. TALK OVER** - Turning this setting on will instantly reduce the volume of the the music while any MIC on any of the three MIC INPUTS are in spoken or sung into. The volume will gradually fade-in once the microphone is no longer in use.
- 10. INPUT** - This button allows you to select between BGM, DVD, CD and AUX player input to the DA-3800 PRO. This allows the DA-3800 PRO to differentiate between all the related source AUDIO INPUT options available on the back panel. If the button is held for approximately one second, the AUTO setting will be selected and highlighted on the display. This mode will have the DA-3800 PRO automatically switch to BGM (Background Music) when the signal from DVD, CD or AUX is stopped. Note: The switch to BGM when the signal stops may take a few seconds.
- 11. MIC MAX** - This control adjusts the maximum output level of the MIC VOLUME control. Turn clockwise to increase the maximum level, counter-clockwise to decrease. Adjust with a flat-head screwdriver.
- 12. MUSIC MAX** - This control adjusts the maximum output level of the MUSIC VOLUME control. Turn clockwise to increase the maximum level, counter-clockwise to decrease. Adjust with a flat-head screwdriver.
- 13. MIC 1, 2, 3 INPUTS** - Connect your 1/4" cabled microphones into any of these three inputs.
- 14. MICROPHONE VOLUME CONTROLS** - These level controls for MIC 1, 2 and 3 should be adjusted individually to get the best mix when multiple performers are singing. Rotate clockwise to increase and counter-clockwise to decrease VOLUME for each mic.

Front Panel Descriptions and Functions cont.

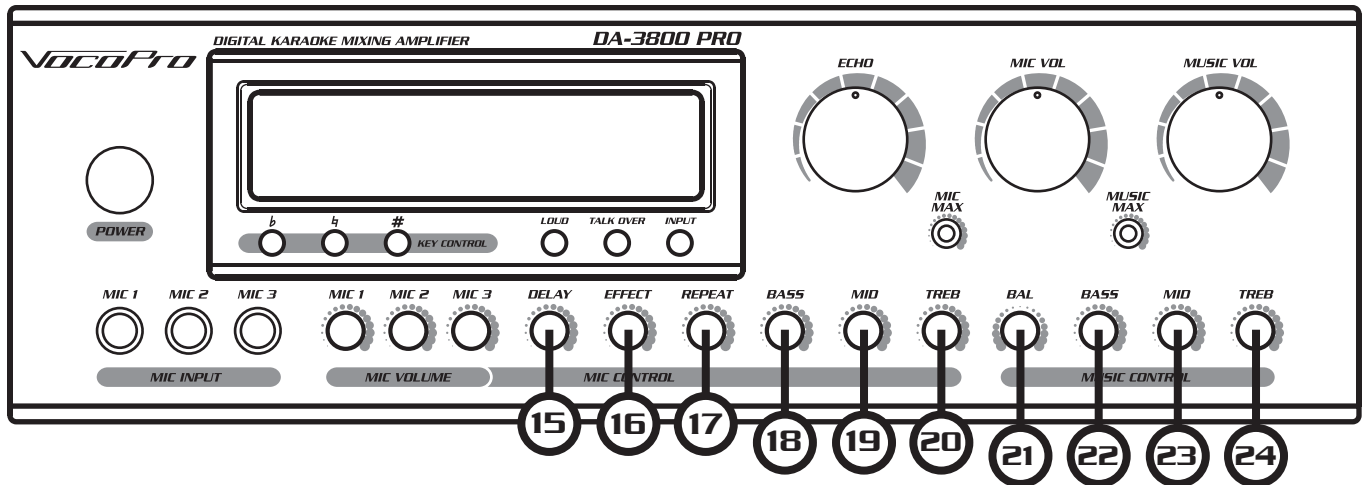

MIC CONTROLS

15. **DELAY** - This control adjusts the length of time for each ECHO interval, or REPEAT. Rotating the DELAY control clockwise will increase the DELAY, creating the effect of more "space."
16. **EFFECT** - This control adjusts the output volume of all echo connected.
17. **REPEAT** - This control adjusts the number of ECHO repeats applied to the signal until the effect decays, or fades out.
18. **BASS** - This control adjusts the low end frequency level of your MIC INPUT.
19. **MIDDLE** - This control adjusts the mid-range frequency level of your MIC INPUT.
20. **TREBLE** - This control adjusts the high end frequency level of your MIC INPUT.

MUSIC CONTROLS

21. **BALANCE** - This control adjusts the balance of the output to the left or right channel.
22. **BASS** - This control adjusts the low end frequency level of your MUSIC source.
23. **MIDDLE** - This control adjusts the mid-range frequency level of your MUSIC source.
24. **TREBLE** - This control adjusts the high end frequency level of your MUSIC source.

Rear Panel Descriptions and Functions



VocoPro
 THE SINGERS ULTIMATE CHOICE™
 La Verne, California U.S.A.
 www.vocopro.com

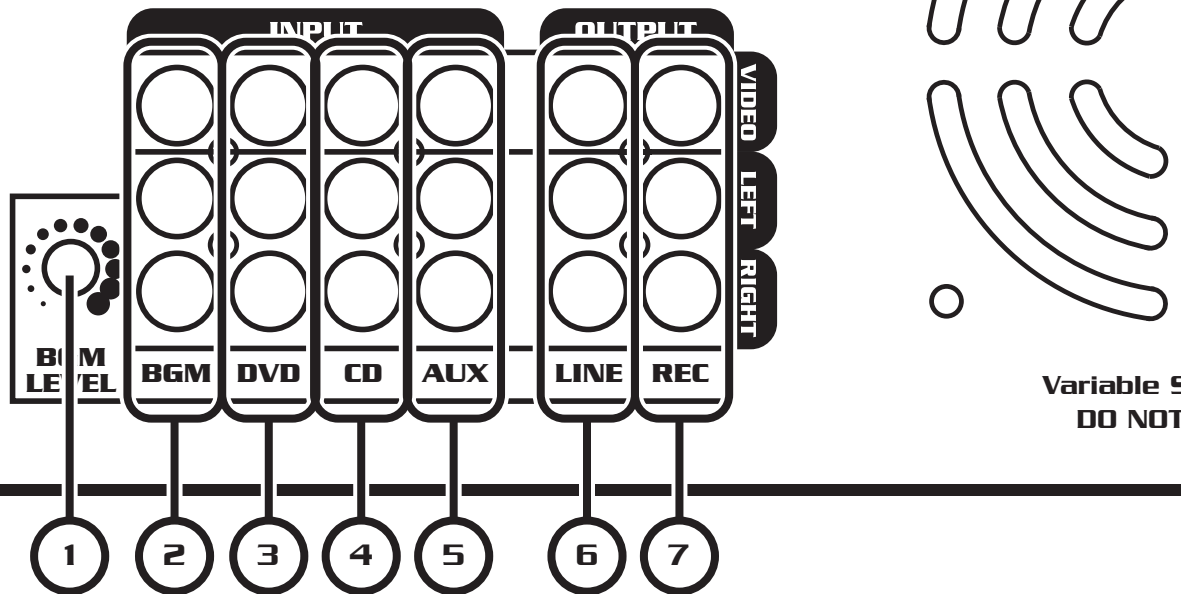

1. **BGM VOLUME CONTROL** - This controls the output level of the BGM (Background Music) source. Turn clockwise to increase output, counter-clockwise to decrease. Adjust with a flat-head screwdriver.
2. **BGM RCA INPUT** - RCA audio/video input for the BGM input channel. Connect here using a standard white/red/yellow RCA cable.
3. **DVD RCA INPUT** - RCA audio/video input for the DVD input channel. Connect here using a standard white/red/yellow RCA cable.
4. **CD RCA INPUT** - RCA audio/video input for the CD input channel. Connect here using a standard white/red/yellow RCA cable.
5. **AUX RCA INPUT** - RCA audio/video input for the AUX input channel. Connect here using a standard white/red/yellow RCA cable.
6. **LINE RCA OUTPUT** - Connect a **standard white/red/yellow** RCA cable from this output to the video input of your TV or other video monitor device and to powered speakers or any device with RCA inputs.
7. **RECORD RCA OUTPUT** - These RCA output jacks are designated for connection to a recording device such as a cassette deck, CD burner or hard drive recorder.

Rear Panel Descriptions and Functions cont.

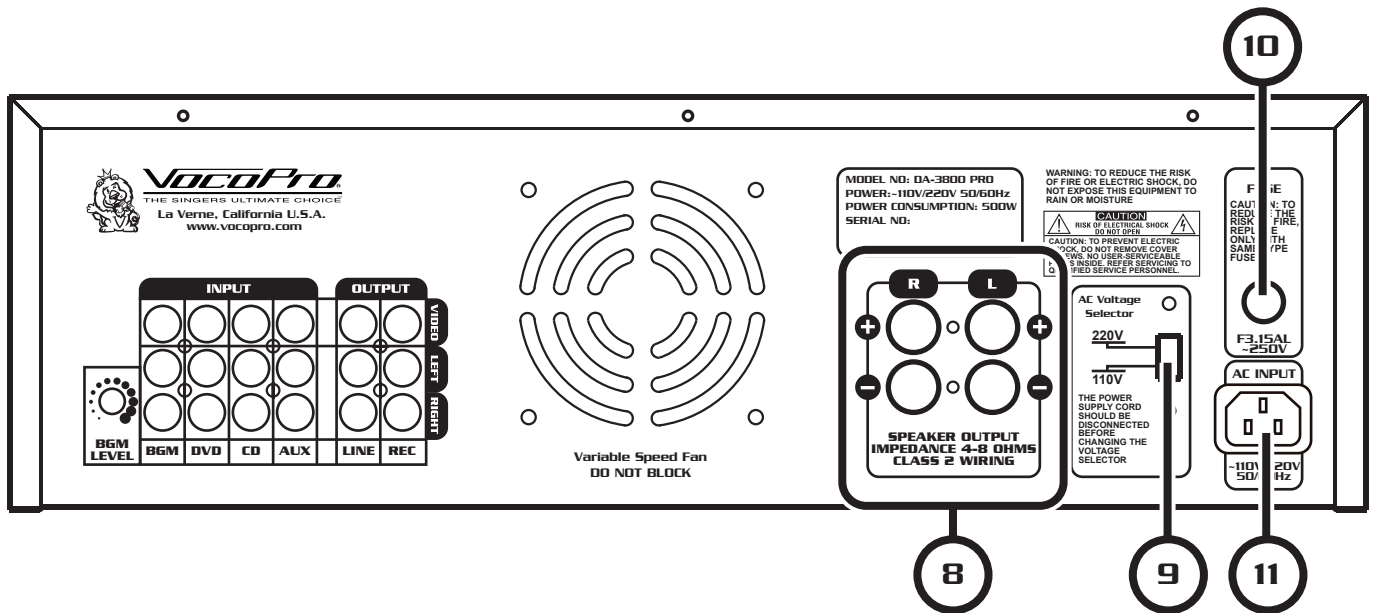

- 8. SPEAKER OUTPUT** - You can connect two different speakers between SPEAKERS OUTPUT L and R. Exposed speaker wire can be used by removing the corresponding left or right knob from the speaker terminal by turning counter-clockwise, inserting the wire and re-insterting the knob and securing it by tightening clockwise. "Banana plug" style speaker cables can also be used for left and right of each pair. Refer to the "Getting Connected" portion of this manual for further information on connecting your speakers and the use of "banana plug" connections.
- 9. VOLTAGE SELECTOR** - Using this switch you can select between 115V and 230V power settings.
NOTE: *The power supply cord should be disconnected before changing the voltage selector.*
- 10. FUSE** - This plastic cover is the housing for the DA-3800 PRO's fuse. Use only FUSE type F3.15AL, 250V when replacing the fuse.
- 11. AC INPUT** - Connect the power cable here.

Remote Control Descriptions and Functions

The maximum operating distance between the Remote Control and the REMOTE SENSOR is approximately 23 feet. If the effective distance of the Remote decreases, replace the batteries. To install new batteries, remove the battery compartment lid on the back of the Remote and insert two AA batteries with polarities aligned.

1. DIGITAL KEY CONTROL - Adjust the key of your source music in half-step increments to match the natural range of your voice using these buttons.

b Flat - lower the key.

Sharp - raise the key.

4 Natural - return to the original key of the music input source.

You will see the DISPLAY reflect the KEY CONTROL step you have selected. The increase in numbers for both flat (*b*) and sharp (*#*) represent an increase in amount of key change from the original or natural, 1 being the least amount, 4 being the most.

2. LOUD (LOUDNESS CONTROL) - For an instant music Volume/Gain, the LOUDNESS button is an easy way to improve your mix when you need an extra boost. Perfect for varying volume controls between tracks or singers.

3. TALK OVER - Turning this setting on will instantly reduce the volume of the the music while any MIC on any of the three MIC INPUTS are in spoken or sung into. The volume will gradually fade-in once the microphone is no longer in use.

4. INPUT - This button allows you to select between BGM, DVD, CD and AUX player output to the DA-3800 PRO. This allows the DA-3800 PRO to differentiate between all the related source AUDIO INPUT options available on the back panel. If the button is held for approximately one second, the AUTO setting will be selected and highlighted on the display. This mode will have the DA-3800 PRO automatically switch to BGM when the signal from DVD, CD or AUX is stopped.

5. ECHO - This control is the overall level for the ECHO effect on all three MIC INPUTS. Use the ▲ to increase the ECHO effect and the ▼ to reduce the ECHO effect. You will see the controls on the DA-3800 PRO move as you make adjustments using the remote keys.

6. MIC VOLUME - Use the ▲ to raise the MIC MASTER VOLUME and the ▼ to lower this mixed MIC MASTER VOLUME. You will see the controls on the DA-3800 PRO move as you make adjustments using the remote keys.

7. MUSIC VOLUME - Use the ▲ to raise the MUSIC VOLUME and the ▼ to lower the MUSIC VOLUME. You will see the controls on the DA-3800 PRO move as you make adjustments using the remote keys.

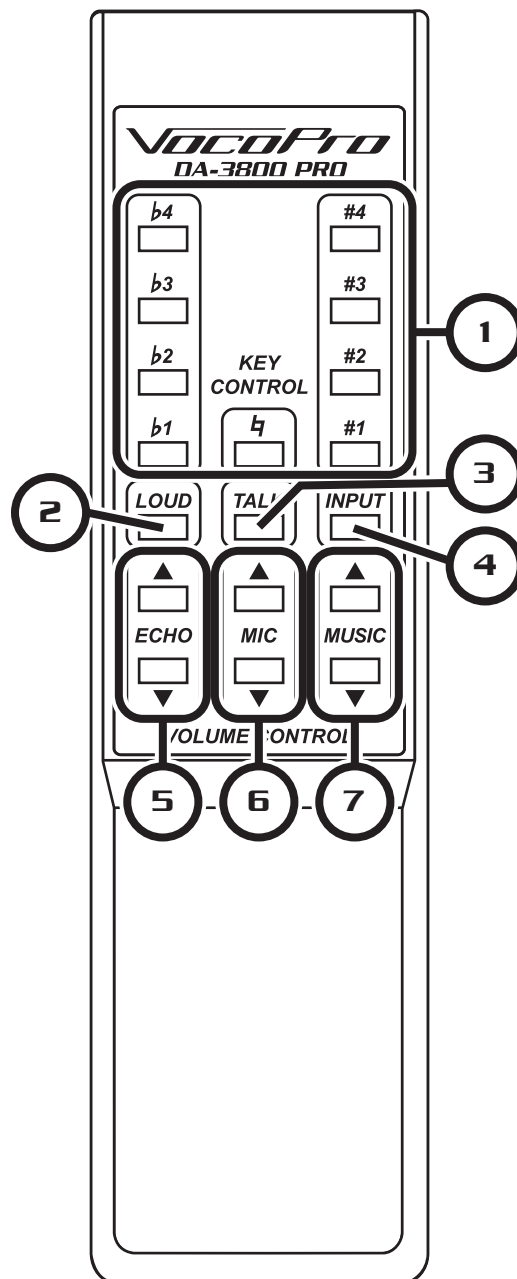

Display Panel Descriptions and Functions

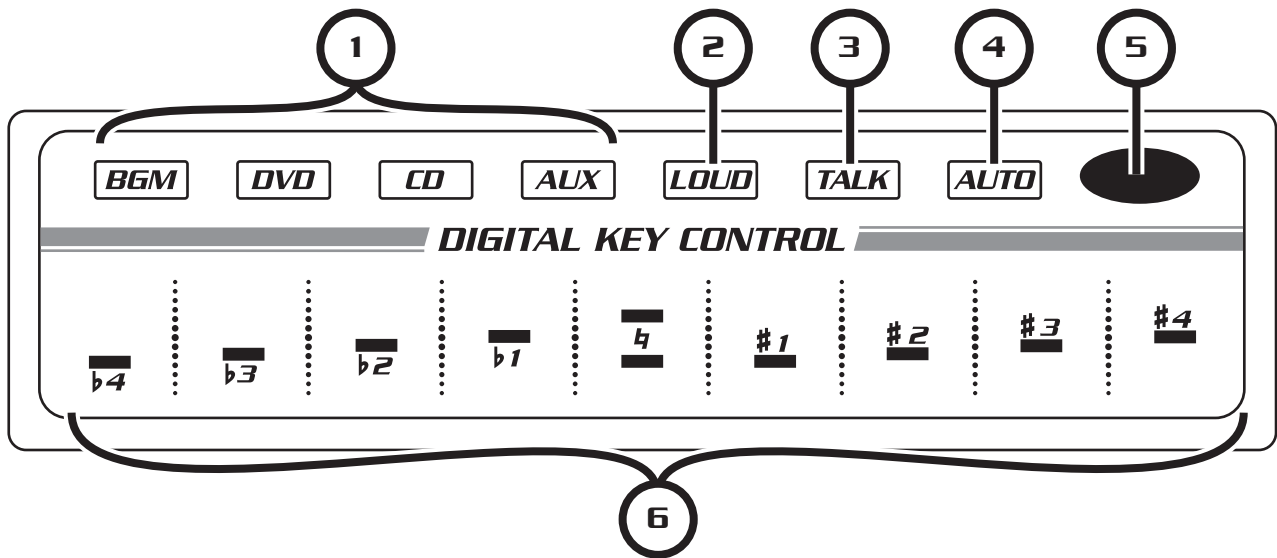

1. **INPUT INDICATOR** - Each of these will illuminate to indicate which input has been selected, BGM (Background Music), DVD, CD and AUX. These correspond to the input channels on the rear of the unit.
2. **LOUD (LOUDNESS CONTROL) INDICATOR** - This indicator will illuminate when the LOUD mode has been enabled. For an instant music Volume/Gain, the LOUD button is an easy way to improve your mix when you need an extra boost. Perfect for varying volume controls between tracks or singers.
3. **TALK OVER INDICATOR** - This indicator will illuminate when the TALK OVER mode has been enabled. Turning this setting on will instantly reduce the volume of the the music while any MIC on any of the three MIC INPUTS are in use. The volume will gradually fade-in once the microphone is no longer in use.
4. **AUTO INDICATOR** - This indicator will illuminate when the AUTO mode has been enabled. This mode will have the DA-3800 PRO automatically switch to BGM (Background Music) when the signal from DVD, CD or AUX is stopped. Note: The switch to BGM when the signal stops may take several seconds.
5. **IR SENSOR** - This sensor receives the infrared signal from the REMOTE CONTROL. When operating the DA-3800 PRO with the REMOTE CONTROL, direct the REMOTE towards this SENSOR within 23 feet. Maintain a line of sight between REMOTE and REMOTE SENSOR clear of obstacles to prevent signal deflection.
6. **DIGITAL KEY CONTROL** - Shows the current key control setting.
 - b* Flat - lower the key.
 - #* Sharp - raise the key.
 - 4* Natural - return to the original key of the music input source.

You will see the DISPLAY reflect the KEY CONTROL step you have selected. The increase in numbers for both flat (*b*) and sharp (*#*) represent an increase in amount of key change from the original or natural, 1 being the least amount, 4 being the most.

DA-3800 PRO Specifications

MAX POWER OUTPUT (1KHz, 8 Ω) 100W + 100W
TOTAL HARMONIC DISTORTION 0.05% (1 KHz, 60W, 8 Ω)

AUDIO

MICROPHONE 12mV/2K Ω
BGM/DVD/CD/AUX 300mV/51K Ω

VIDEO

DVD/ AUX / CDG 1V P-P/75 Ω

FREQUENCY RESPONSE

MIC 40Hz-15kHz \pm 3db
MUSIC 20Hz-20kHz \pm 2db

TONE CONTROL (MUSIC / MIC)

BASS \pm 12dB (100Hz)
MID \pm 8dB (2KHz)
TREBLE \pm 12dB (10KHz)

SPEAKER IMPEDANCE

ONE CHANNEL (1 OR 2) 4 - 16 Ω
TWO CHANNELS (1 AND 2) 8 - 32 Ω

POWER SUPPLY, OTHER

POWER REQUIREMENTS AC 110V/220V 50Hz/60Hz
POWER CONSUMPTION 350 WATT

DIMENSIONS

(W x D x H): 430mm x 360mm x 130mm (16.93in x 14.17in x 5.12in)
WEIGHT 7.5 Kg (16.5 lbs)

ACCESSORIES

AC POWER CORD 1
RCA CABLES 1
OPERATING INSTRUCTIONS 1
REMOTE CONTROL 1
BATTERIES AA 2
WARRANTY CARD 1

Troubleshooting

No sound output.	<ul style="list-style-type: none">• Make sure the DA-3800 PRO is set to the correct input.• Make sure the volume is turned up.• Make sure everything is connected firmly and properly.• Make sure there are no defective cables.• Make sure all of your components are turned on.
No sound output when BGM source is playing.	<ul style="list-style-type: none">• Make sure the DA-3800 PRO is set to the BGM input.• Make sure the rear BGM volume is turned up.
There is music but no microphone vocals.	<ul style="list-style-type: none">• Make sure the microphone is turned on.• Make sure the microphone cable is not disconnected or damaged.• Make sure the microphone master volume or individual microphone volume controls are turned up to the proper level.
The remote control is not working.	<ul style="list-style-type: none">• The DA-3800 PRO power is not on.• Make sure the batteries are inserted correctly and not out of power.• Make sure there is nothing blocking the view between the remote control and the remote sensor on the front of the DA-3800 PRO.

NOTES

VocoPro[®]

THE SINGER'S ULTIMATE CHOICE[™]

